



Parts Cleaning. Systems and Solutions.



Purely energy-efficient.



Energy-efficient
parts cleaning and drying
on an aqueous basis

In view of rising energy costs and the constantly increasing competition, the sustainable operation of production lines is becoming more and more important. This situation, as well as the endeavour to reach climate targets, calls upon companies to identify and utilize energy-saving potential on their shop floors. It has always been MAFAC's goal to develop ecological processes and machine technologies. This is evident for example in the patented

counter- or co-rotation of basket and nozzle systems, or the various developments in the frame of the ETA Factory by Darmstadt PTW. In the parts cleaning sector, MAFAC designed a number of features on the machine and the process side which allow the user to save energy as well as money.

1 Kinematic cleaning and drying

Compared to stationary nozzle systems, the patented MAFAC process of co- or counter-rotation of basket and nozzle system offers significant potential for saving energy and time. In terms of the process-specific energy requirements of the machine, up to 30% of the energy can be saved in the cleaning process and even up to 42% in the drying process. These values were determined by internal comparison tests with MAFAC machines with standardized parts in a standardized process. All standard versions of the MAFAC cleaning machines are equipped with the rotational cleaning feature, while rotational drying is available as an option.

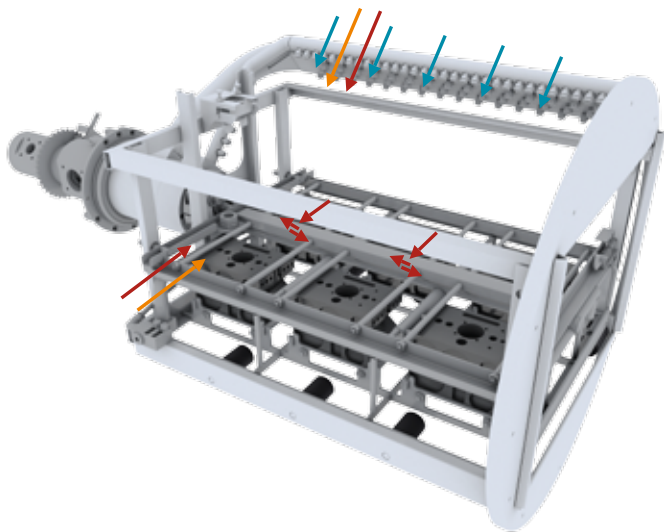
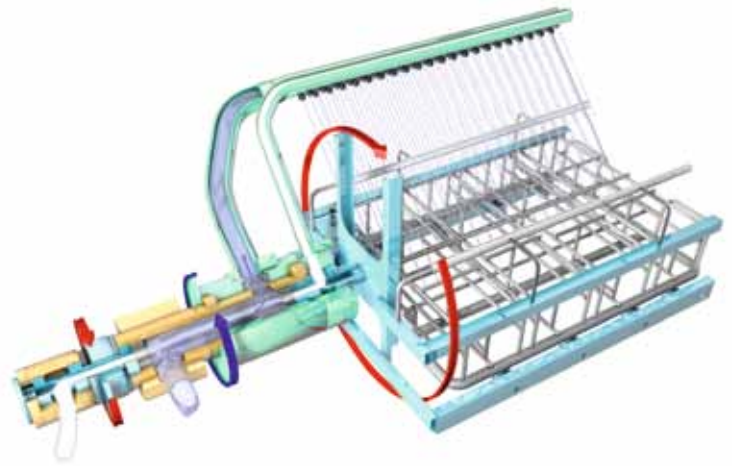

2 Targeted global and partial cleaning and drying

When cleaning parts with complex geometries, it is often the case that valuable resources and much time are invested with the result that the easy-to-access parts are „overcleaned“ before the hidden interior contours are cleaned in accordance with the requirements. To address this problem, MAFAC developed a new process for partial targeted cleaning, rinsing and drying. When combined with the rotating basket and nozzle system, it offers the user additional potential for saving time and energy. The process requires a workpiece positioning system individually adjusted to the customer's needs. Currently, it can be used with the MAFAC JAVA and MAFAC PALMA.



3 Full heat insulation

The insulation of the entire machine including doors, units, flow ducts and holding tanks reduces the machine's thermal energy requirement by 29%. This was shown in the ETA Factory via comparing a standardized process run without parts load in a fully insulated and a non-insulated MAFAC JAVA. Additionally, insulation reduces the heat emission by 40%, resulting in lower costs for air conditioning on the shop floor. Furthermore, the A-weighted sound pressure level is reduced by 9%. Both factors significantly improve the working conditions on site. Full heat insulation is available as an option.

4 Internal use of the specific heat of the machine for pre-warming and drying air

The full heat insulation of a machine brings additional energy savings of 2.5 to 4% (in relation to the total energy requirement) by recuperating the specific heat of the machine for pre-warming the air used in hot air flow drying. These savings are included in the calculation in Pos. 3.



5 Using the existing external heat for heating the holding tanks

For heating the holding tanks, alternative sources such as hot water from the heat treatment, co-generation, and regenerative water heating applications (solar heat) can be used. They can be integrated by means of the heat exchange module MAFAC HEAT.X. Thus, using existing heat can reduce the energy consumption for heating bath 1 (which as a rule consumes more than 90% of the total thermal energy required) by more than 90% and also lower the respective CO₂ emissions. The heat exchanger module is available now and is easy to retrofit in existing machines.

6 Process intelligence sensors

Intelligent hardware and software solutions can stabilize peak loads and avoid the simultaneous operation of processes. This can save approx. 1% of the total energy consumption.

7 Internal recuperation of exhaust heat for fresh water pre-warming via bionic dehumidification

Bionic dehumidification is a current development project of MAFAC's. It not only lowers the energy consumption for fresh water pre-warming but also reduces heat emission by up to 90% and aerosol emission by up to 80%, which benefits the working conditions on site and the environment. Employee health is furthermore significantly improved by the removal of particulate and film contamination in the exhaust air and the elimination of odours.

8 Training and process optimisation

Well-trained employees who service the machines and check the processes in regular intervals also greatly contribute to successful resource saving. In case of changed requirements or after many years of operation, a process optimisation by MAFAC is recommended. In many cases, savings potentials of up to 5% of the total energy consumption can be identified, followed by the corresponding process optimisation.

Saving energy costs

The following example explains the relevant savings potential:

In comparison with a MAFAC JAVA with electric heating and without rotation and full heat insulation, running in 3-shift operation with 6 batches per hour, a process time of 550 sec., a cleaning temperature of 75°C and loaded with steel parts with a total weight incl. basket of 70 kg, and the cleaning process: spray cleaning, spray flooding, spray rinsing, pulse blowing, and hot blowing.

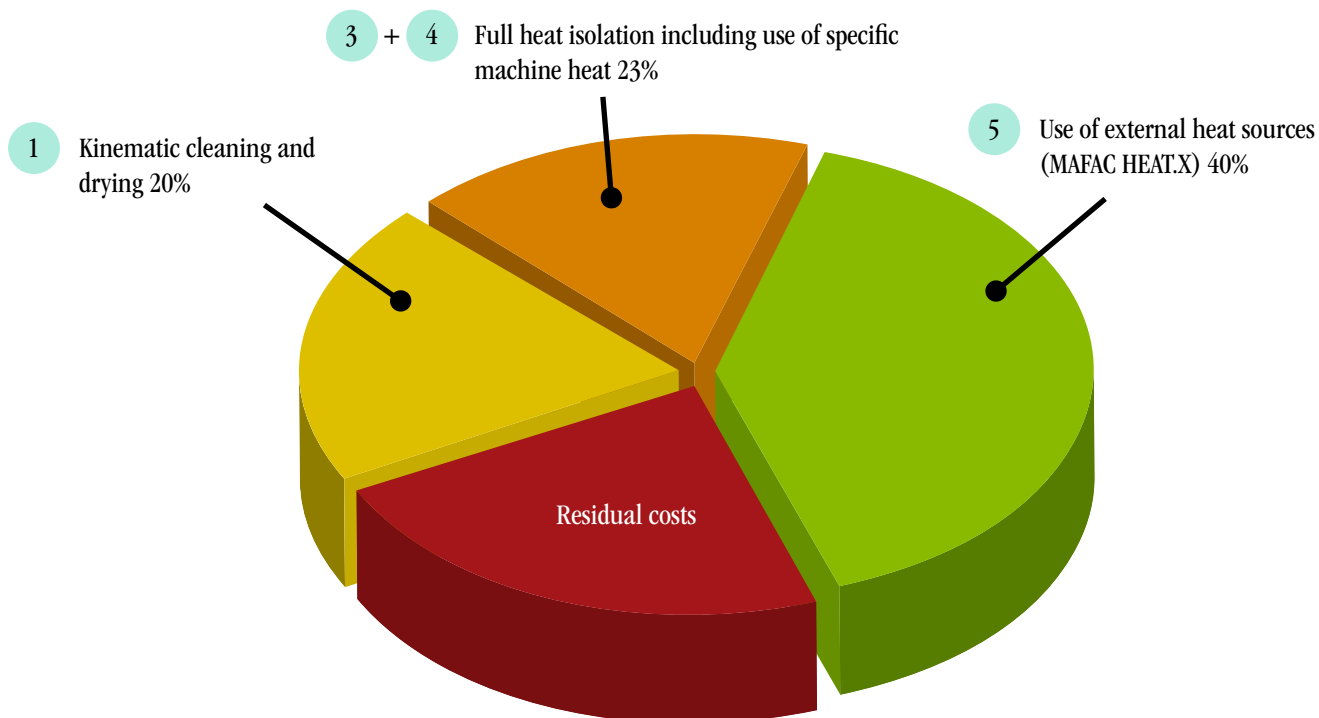

Savings up to 83% are possible!

Amortisation

Including the capital expenditure for the individual options in the calculation, the investment has a payback period of just 2 years, depending on the option and the level of utilisation of the machine.

Reduction of CO₂ emissions

In this example, CO₂ emissions are reduced by approx. 46 tons per year.

We will happily develop an energy efficiency concept for your existing or future machines in close cooperation with you. With our help, you will save money, reduce your CO₂ emissions, improve the working conditions for your employees and protect the environment.

